



UNDER ROOF TROUGH ROLLER CONVEYORS

Doyle Overhead Trough Roller Conveyors, Tripslingers and Gravity Trippers are built for dependability, longevity and speed. Toward that end, all items are built out of type 304 stainless whenever possible. Stainless items include guards, belt adjusters, and motor mounts.

If you need a quality conveying system, look no farther than Doyle.

20" Shown With Tripslinger

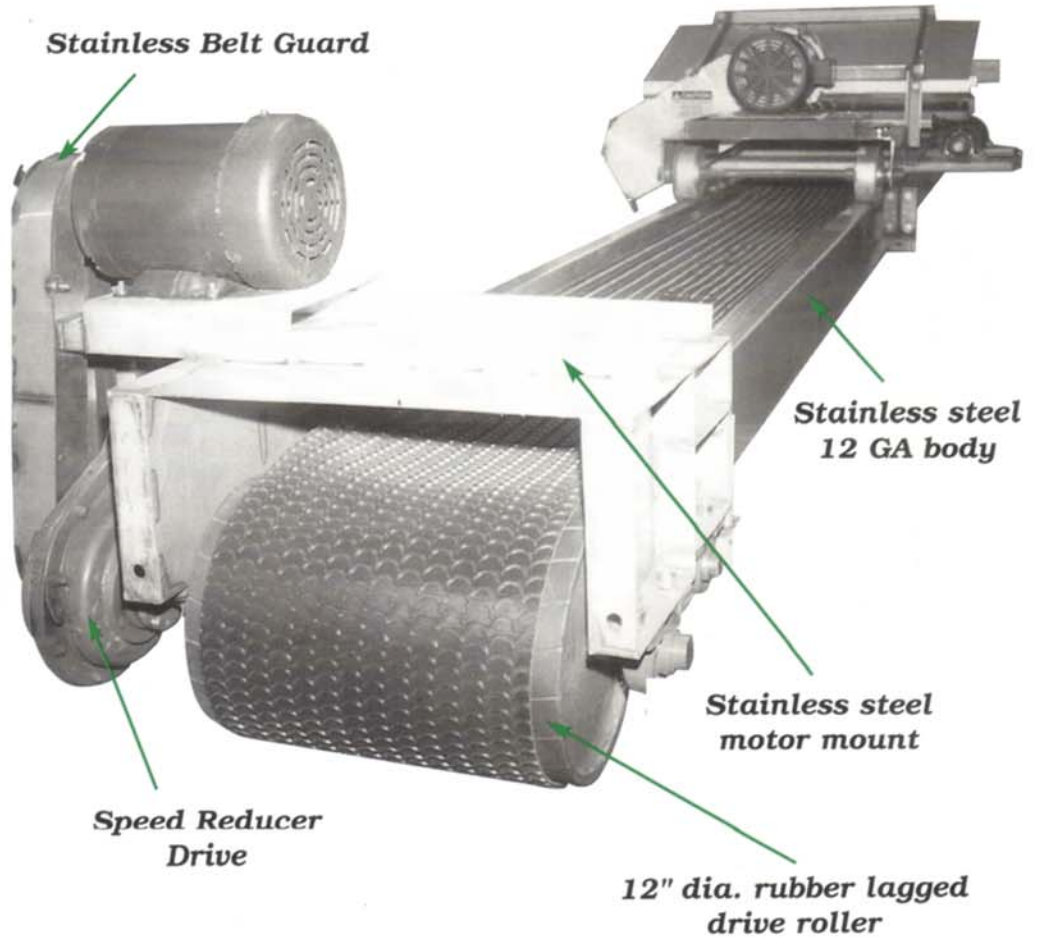

Trough Cross-Section

Belting PVC Roller



12 GA Stainless

2 Way Gravity Tripper

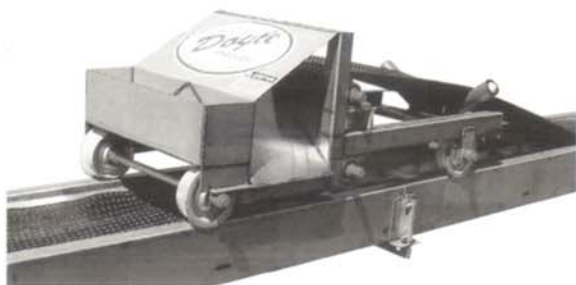

Tripslinger

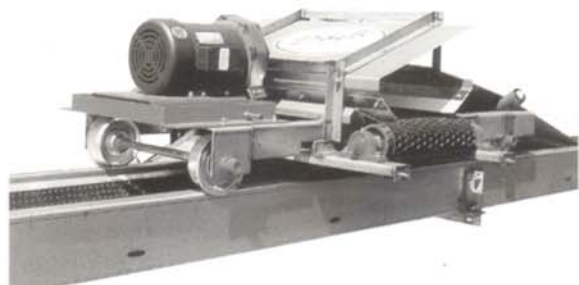

Shuttle Conveyors

Doyle Shuttle Conveyors are built in 16" and 20" belt widths and feature a sturdy 12 GA stainless steel troughing body. The conveyors roll on stainless caster mounts with HD cast iron flanged greaseable bearing wheels, spaced approximately every 16'. Standard is a speed reducer drive, stainless motor mount, and stainless guards.

If you need a quality conveying system, look no farther than Doyle.

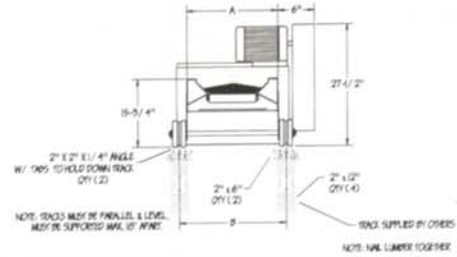
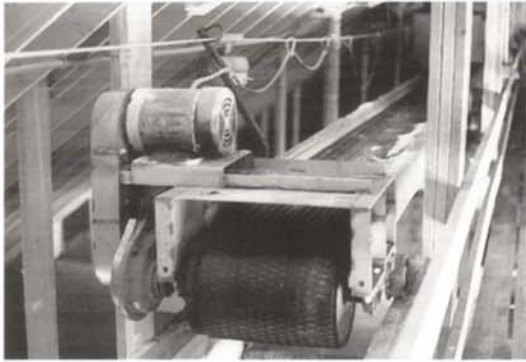

Belt	Dim. A	Dim. B
16"	21"	23 3/4"
20"	25"	27 3/4"

Trough Roller Conveyor & Tripper Specifications

Doyle offers three styles of trippers: 1) The two way gravity tripper trips material off of the conveyor wherever the tripper is located. All product must leave the conveyor at that point. 2) the three way gravity tripper trips material off of the conveyor wherever it is stationed, plus it can discharge left OR right, OR allow material to bypass it and continue on, where it will discharge off of the end of the conveyor. 3) The Tripslinger "slings" material off of the conveyor wherever it is stationed, through the use of a high speed, reversing belt.

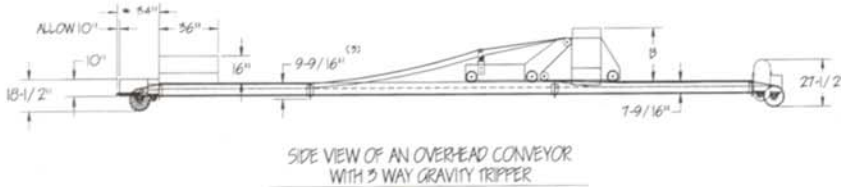
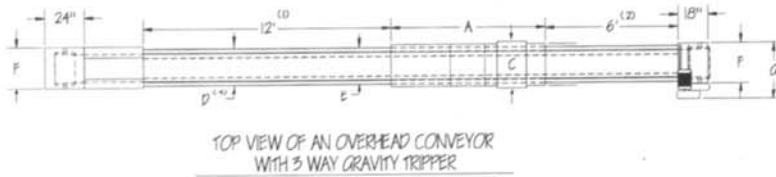

Notes: 1) Min. distance, tripper to inload hopper. 2) Min. distance, tripper to head section. 3 & 4) Conveyor flange outside dimension.

Conveyor	Tripper	A	B	C	D	E	F	G	H
16"	2 Way Gravity Tipper	55"	20 1/2"	25 1/2"	25"	21"	26"	32"	32"
16"	3 Way Gravity Tripper	94"	37"	33 1/8"	25"	21"	26"	32"	32"
16"	Tripslinger	71 1/2"	22 1/2"	49"	25"	21"	26"	32"	32"
20"	2 Way Gravity Tripper	55"	20 1/2"	25 1/2"	29"	25"	30"	36"	36"
20"	3 Way Gravity Tripper	94"	37"	33 1/8"	29"	25"	30"	36"	36"
20"	Tripslinger	71 1/2"	22 1/2"	49"	29"	25"	30"	36"	36"

Doyle Conveyor Head & Tail Rollers

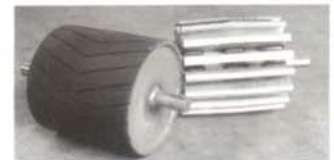

(L) Doyle head roller is 12" dia. w/ vulcanized rubber lagging. (R) Tail roller is also 12" dia., is made of stainless, and is self-cleaning.



Doyle Equipment Mfg. Co., Inc.

P.O. Box 3024 • 3900 Broadway

Quincy, Illinois, USA 62305

217-222-1592, Fax 217-223-3655

E-mail: doyle@rnet.com • Website: www.doylemfg.com